

# Scintillation Counters

We have seen that photons are produced in deexcitation of primary radiation, scintillation devices rely on enhancing and detecting these photons. The primary ionization is ignored and these materials are generally insulators.

## General requirements:

- Linear conversion of  $dE$  into photons
- Efficient conversion into (near) visible light  
(e.g., NaI: 38k/MeV a value similar to  $N_{IP}$ )
- Transparent to scintillation photons, good optical medium
- Short decay time for fluorescence (ns OK, ps good)
- Good mechanical properties ( $n \sim 1.5$  for glass)

## Scintillator classes:

Organic molecules – molecular transitions in fluor

Inorganic materials – transitions in atomic dopants

Molecular energy cycle for photon absorption/emission:  
Notice that there is always a ‘red-shift’ in the emitted photons – energy loss, inefficiency!

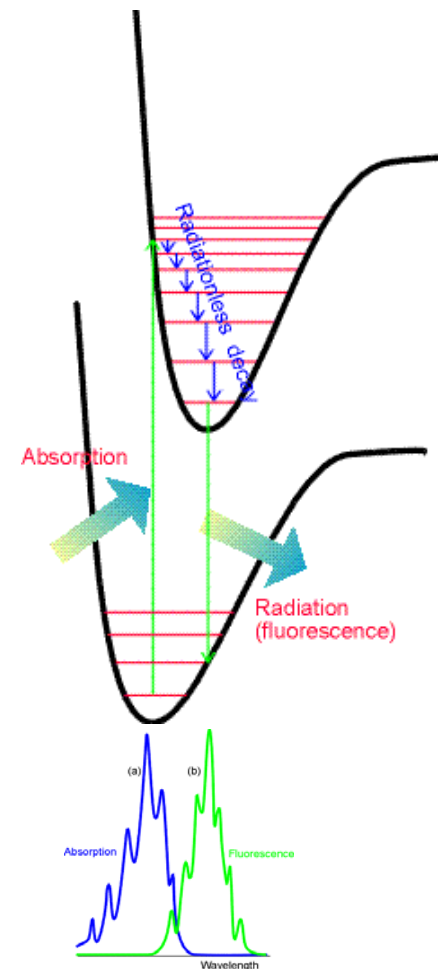

# Scintillation Counters – Organic Materials

Anthracene is (for historical reasons) the standard organic scintillator, it can be crystallized in pure form and packaged for use as a detector.  $\sim 2 \times 10^4 \text{ hv} / \text{MeV}$

- Ground state: *singlet* (all electrons are paired)
- Dipole photon excitation shown to *singlet states*
- Rapid vibrational transitions to  $S_{1-0}$  state followed by dipole transition to ground electronic states  $S_{1-x}$

## Fluorescence

- Occasional intersystem crossing Singlet  $\rightarrow$  Triplet
- Slow spin-flip transition to ground electronic states

$T_{1-0} \rightarrow S_{1-x}$  Phosphorescence

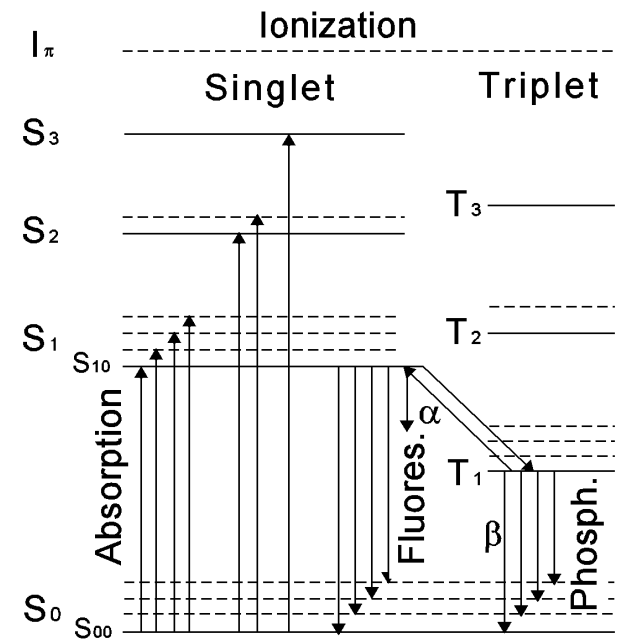
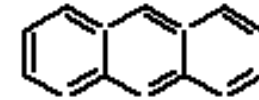
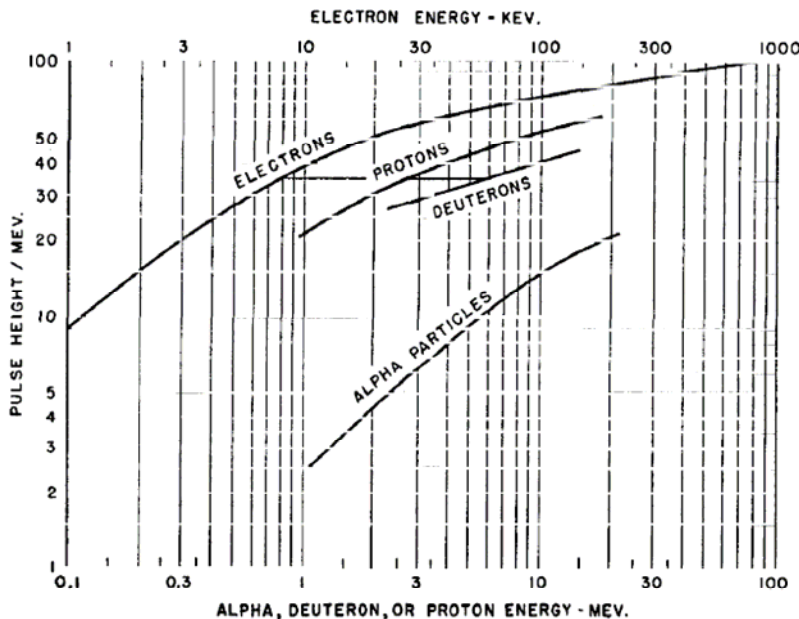

The amount of light and the fraction that ends up in the slower transitions depends on the molecule and on the excitation mechanism.

# Scintillation Counters – Light output

Time distribution usually has two components ... fast one (dipole,  $\tau \sim \lambda^2$ ) and then an exponential decay, additional exponential components are possible if there are other nearby triplet states. Changes in the feeding of the triplet state will change the decay shape ...

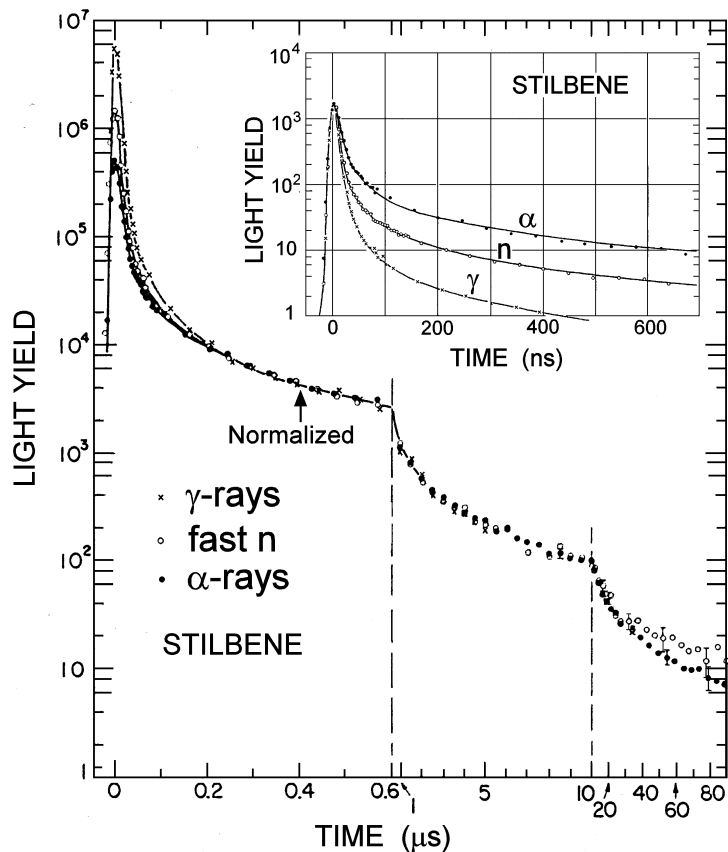

Inset: Fig. 8.5 Knoll, 3<sup>rd</sup> Ed.

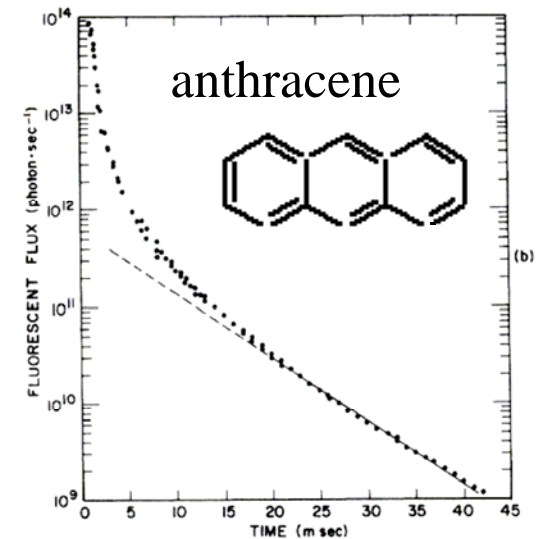
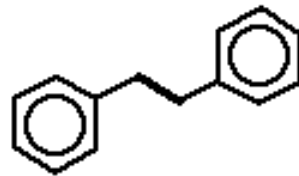

From R.G. Kepler, et al. *Phys.Rev.Lett.*10 (1963) 400

Organic scintillators rely on the molecules in solution to emit the photons. These molecules will be damaged by the primary radiation and lead to a finite lifetime for the detector.  
 $10^3 - 10^4$  Gray  $\rightarrow 10^{+12} - 10^{+14}$  MeV/g

# Scintillation Counters – Inorganic Materials – 1

The band theory of solid materials in one sentence: the regular structure of the lattice and close proximity of atoms allows electron “molecular” orbitals that extend over the entire lattice whose energies merge into bands that preserve the underlying atomic orbital energy pattern.

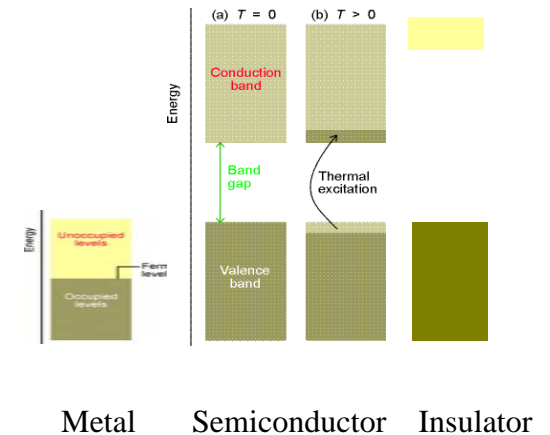
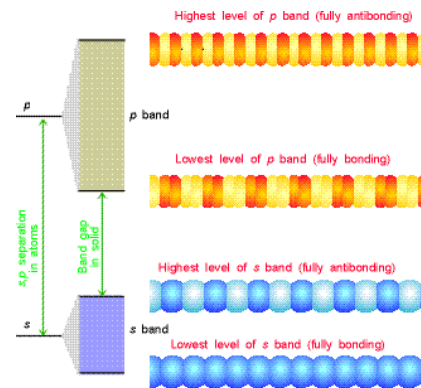

The primary radiation creates an electron/hole pair which can recombine in various ways depending on the material and dopants or activators. The energy necessary to create the pair is about 1.5-2 times the gap in ionic crystals and twice this in covalent materials.

- Form an *exciton* (bound yet mobile e/hole pair) that decays directly, CdS
- Interleaved band structure of anions/cations in lattice, BaF<sub>2</sub>
- Electron (or hole) is trapped by impurity with levels in band-gap, NaI(Tl)

All of these processes emit photons with energies less than the size of the band gap. The dopant is chosen to provide visible photons.

# Scintillation Counters – Inorganic Materials – 2

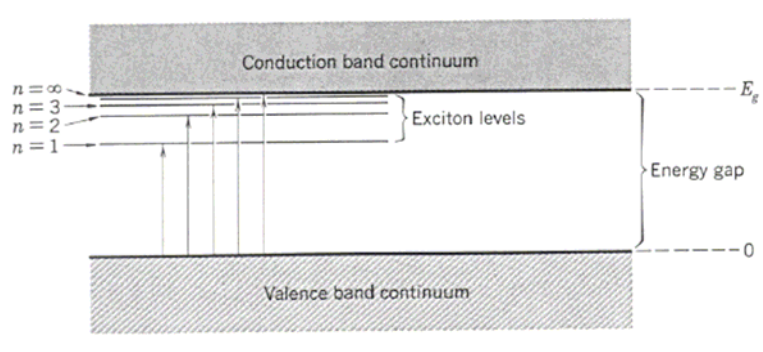

The exciton system, bound e-/hole

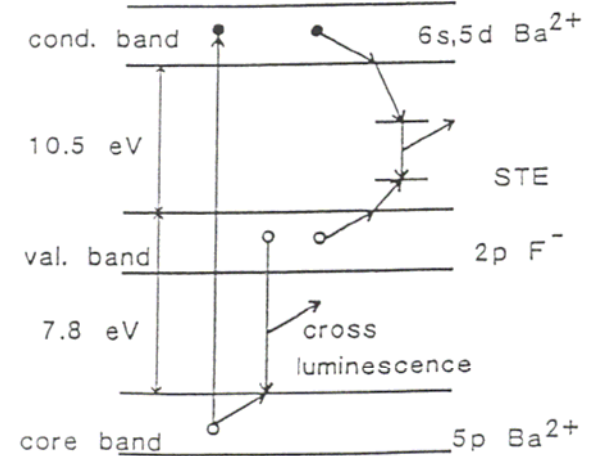

Core-valence transition, & conduction-valence trans.

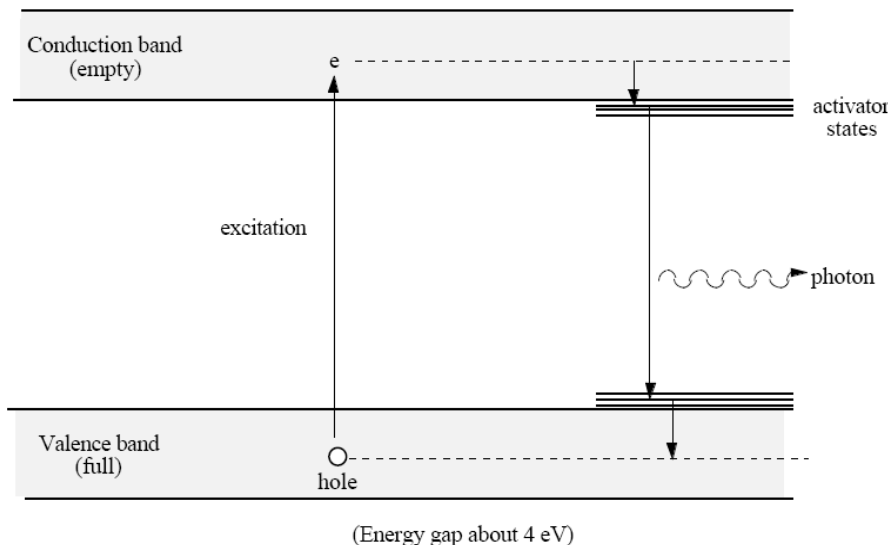

NaI – transition by *Tl* dopant

Note that the amount of excitation energy will be random, the energy above the bottom of the conduction band is lost (thermalized) as well as that below the top of the valence band. This loss is not important if the energy is efficiently transferred to the dopant and if the dopant has a high quantum efficiency.

# Scintillation Counters – Light output: color

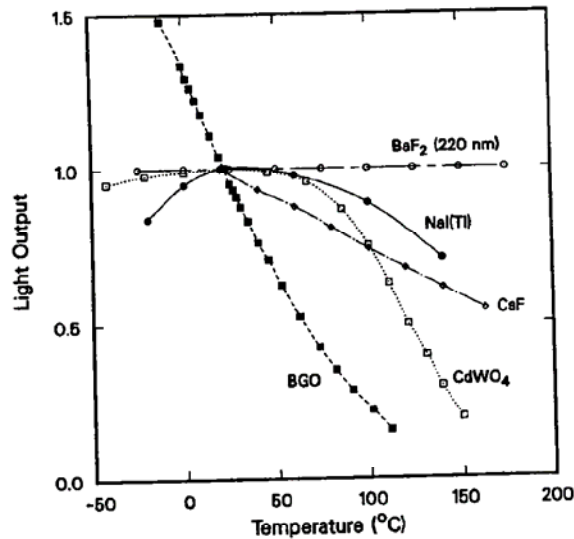

Fig. 8.12 Knoll, 3<sup>rd</sup> Ed.

The emission spectrum of the material should match the spectral response of the photon detector for maximal efficiency ... (obvious)

Cooling the material leads to higher light output, less loss through other processes. (trapping, etc.)

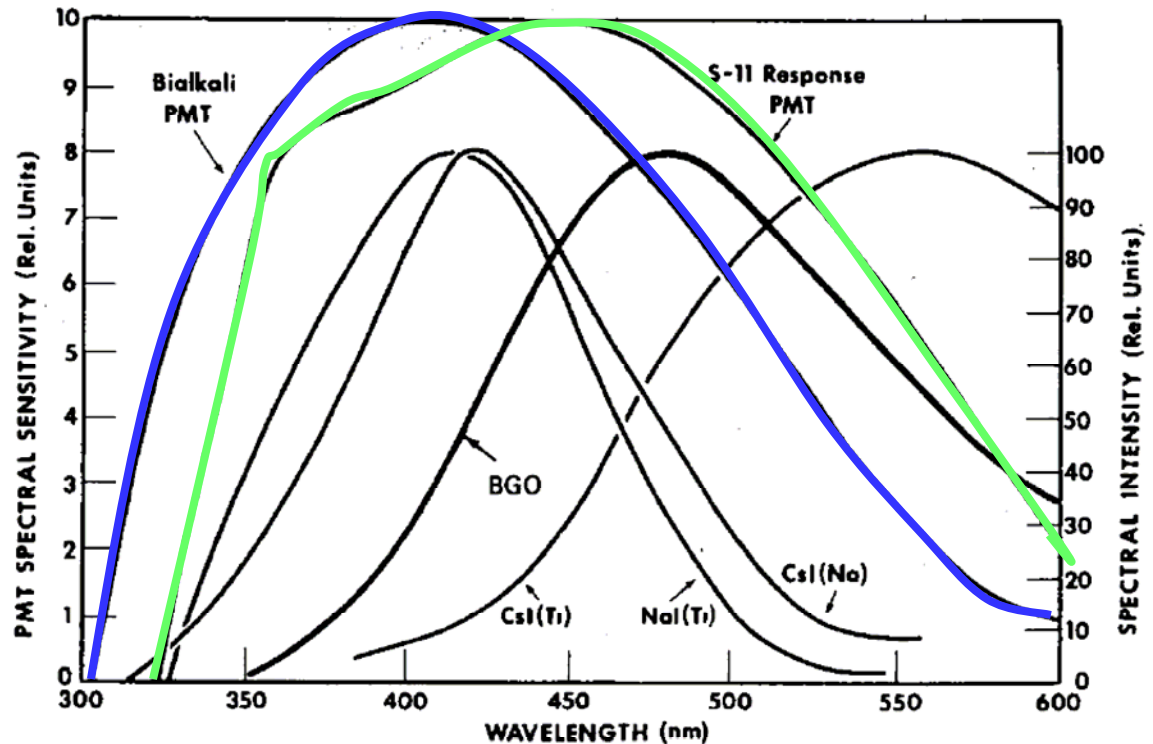
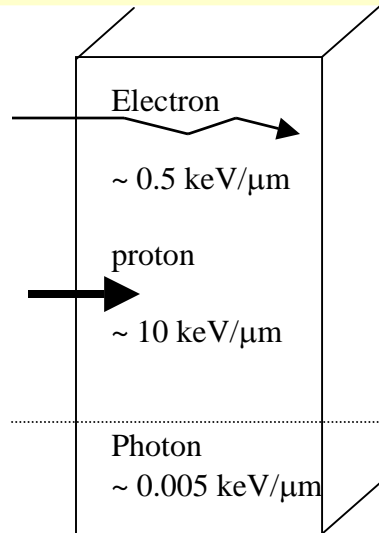

Fig. 8.7 Knoll, 3<sup>rd</sup> Ed.

# Scintillation Counters – Light output/Track



Consider the light output as a function of track length for three particles with 1 MeV incident on a (organic) scintillator:

$$\frac{dL}{dx} = S \frac{dE}{dx} \quad \text{no recombination, etc.}$$

where  $S$  is the sensitivity of the material. In reality:

$$\frac{dL}{dx} = S \frac{dE}{dx} / \left( 1 + kB \frac{dE}{dx} \right)$$

$$\frac{dL}{dx} = S \frac{dE}{dx} \quad \text{when} \quad \frac{dE}{dx} \text{ is small}$$

$$\frac{dL}{dx} \left( \frac{dE}{dx} \right)^{-1} = S \quad \text{or} \quad \frac{dL}{dE} = S$$

$$\int dL = \int S dE \quad \rightarrow \quad L = S * E$$

$$\frac{dL}{dx} = \frac{S}{kB} \quad \text{when} \quad \frac{dE}{dx} \text{ is large}$$

$$\int dL = \int \frac{S}{kB} dx \quad \rightarrow \quad L = \frac{S}{kB} x$$

N.B. “k” and “B” are multiplied together and thus there is really only one constant.

# Scintillation Counters – Light Transmission

Round solid tube – light guide or scintillator – light pipe

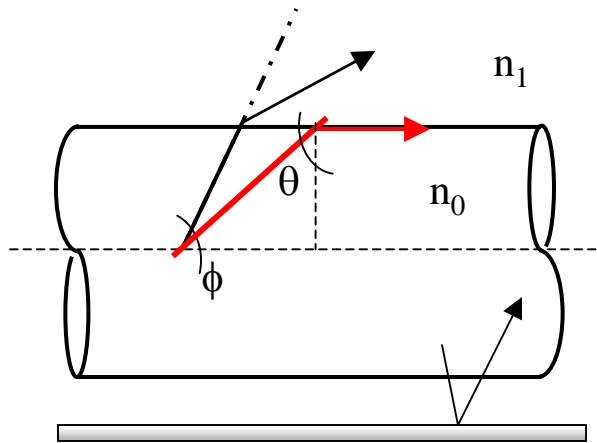

Reflector – specular or *diffuse*

Internal reflection of light up to some critical angle,  $\theta_c$  where  $\sin \theta_c = n_1/n_0$  note that  $\theta_c$  is normal to surface.

$$f = \frac{\Omega}{4\pi} = \frac{1}{4\pi} \int_0^{\varphi_c} 2\pi \sin \varphi d\varphi \rightarrow f = \frac{1}{2} (1 - \cos \varphi_c) = \frac{1}{2} \left( 1 - \frac{n_1}{n_0} \right)$$

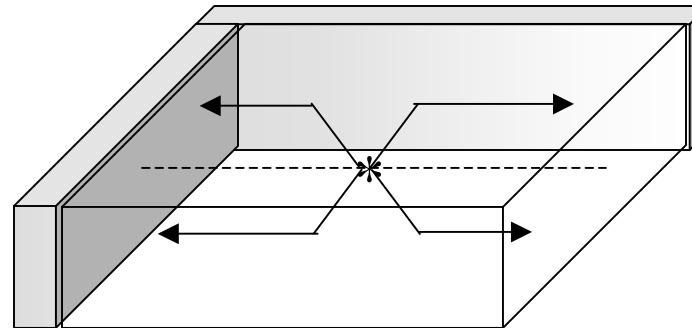

Slab: All edges

$$f = \frac{1}{2} \sqrt{1 - \left( \frac{n_1}{n_0} \right)^2}$$

Attenuation Length: the light will suffer a Beer's Law attenuation along the path  $I = I_0 e^{-x/L}$  where "L" is a characteristic attenuation length. L=2 m is good

Scintillation efficiency or "Sensitivity": the energy in the emitted photons compared to the energy of the incident radiation.  $S = N_{hv} * (hc/\lambda) / E_{incident}$

# Scintillation Counters – Comparison

## Inorganic

## Organic

Mechanism	Excitons recombine at dopants/color centers	Deexcitation of molecular $\pi$ -electrons
Efficiency	Wide range: 0.1 NaI(Tl), 0.001PWO	Narrow range: 0.02 – 0.04
Track quenching	Small	Large
Time constant	Slow ( $\sim \mu\text{s}$ )	Fast (tens of ns)
Temperature dependence	Large	Small
Radiation Damage	Creation of long term trapping centers	Destruction of primary fluors
Density	Generally high, 3.67 NaI(Tl), 8.28 PbWO <sub>4</sub>	Always low, 1 g/cm <sup>3</sup> $\sim$ CH <sub>2</sub>
$\gamma$ -ray detection	Important	Nearly insensitive
Pulse-shape discrimination	Possible in some cases	Fast/slow for $\gamma/n$