

Exam 1 Results

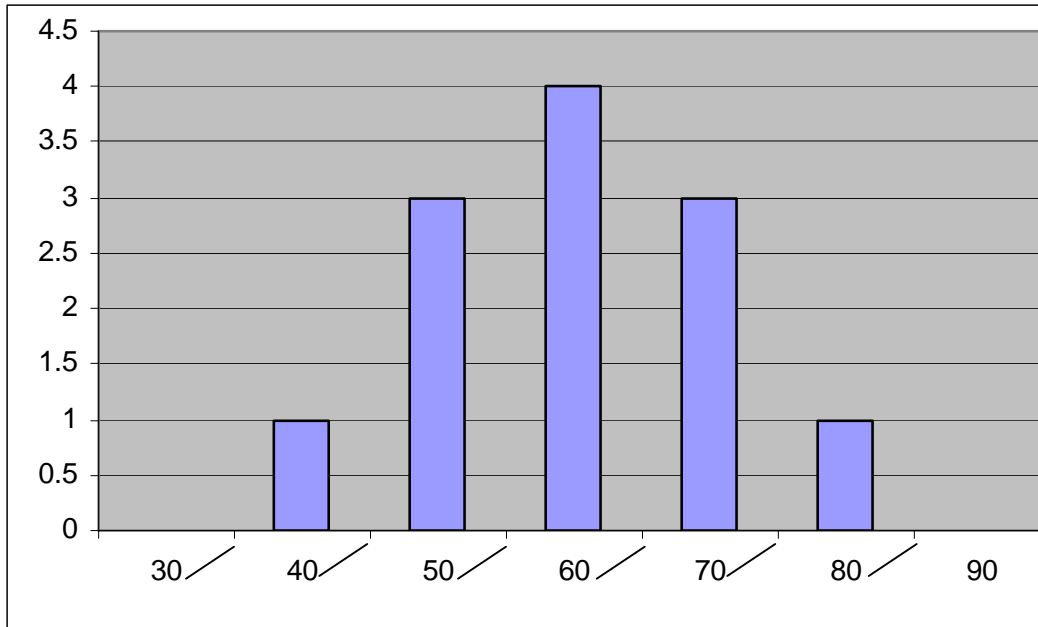

Chap. 13 – Other Semiconductors

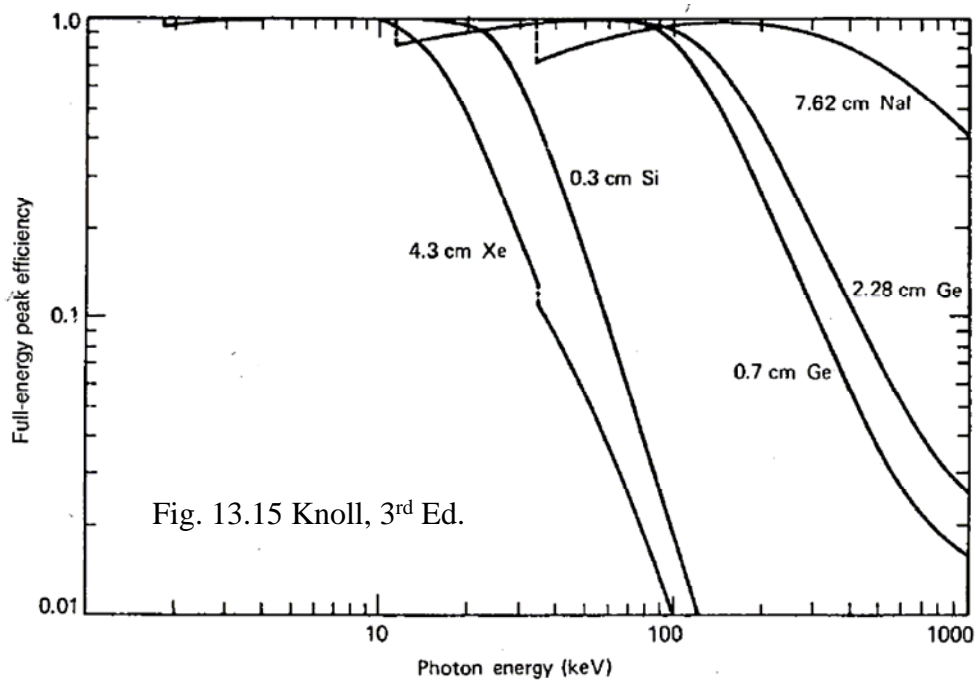

Detector comparison, (thickness given)

NaI(Tl) has a significantly higher stopping power for ~ MeV gamma rays than Ge and especially Si – significant effort has been applied to finding other semiconducting materials with higher atomic numbers.

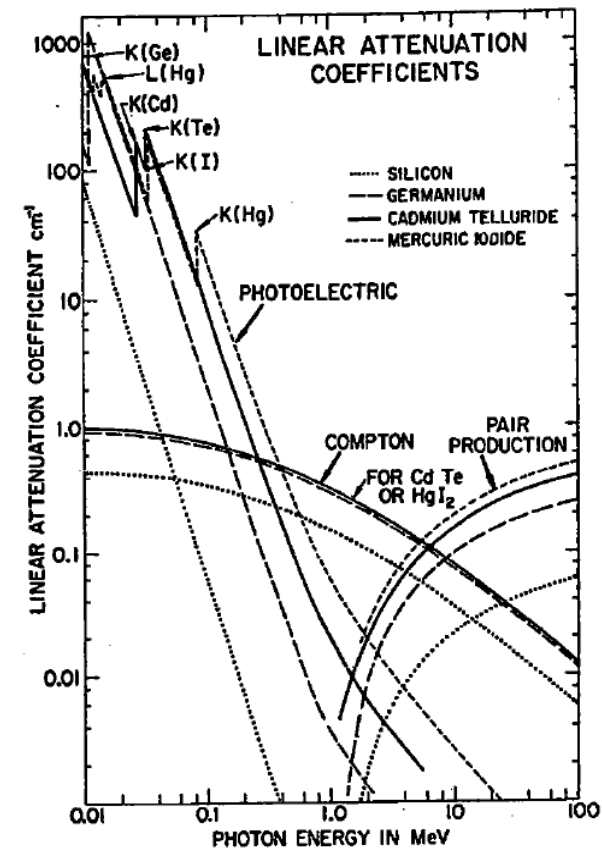
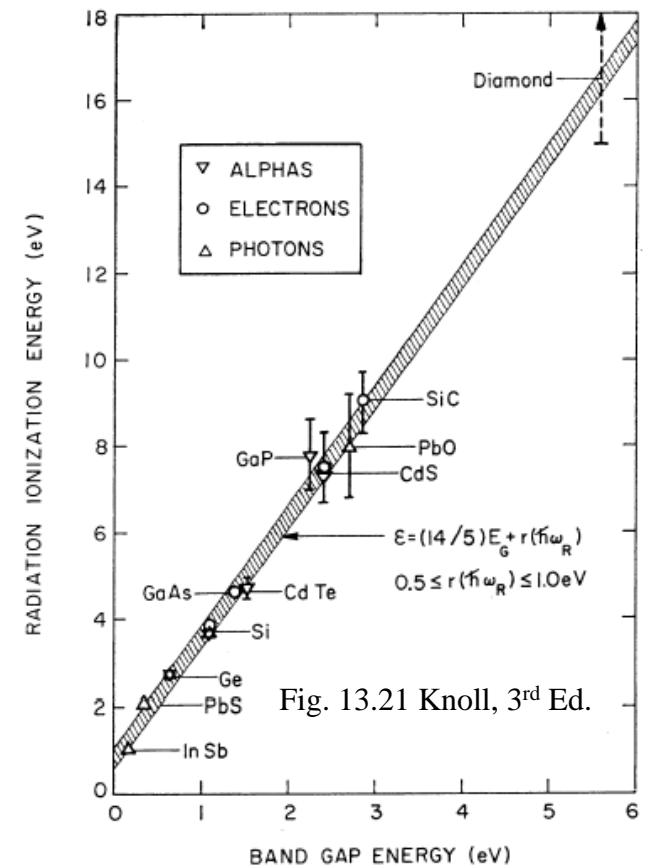

Fig. 13.22 Knoll, 3rd Ed.

Chap. 13 – Other Semiconductors

Material	Z	Bandgap [eV]	Mobility [cm ² /Vs]		Density g/cm ³
			electrons	holes	
Si	14	1.1	1350	480	2.3
Ge	32	0.7	3800	1800	5.3
Diamond	6	5.5	1800	1200	3.5
GaAs	31-33	1.5	8600	400	5.4
AlSb	13-51	1.6	200	700	4.3
GaSe	31-34	2.0	60	250	4.6
CdSe	48-34	1.7	50	50	
CdS	48-16	2.4	300	15	4.8
InP	49-15	1.4	4800	150	
ZnTe	30-52	2.3	350	110	
WSe ₂	74-34	1.4	100	80	
BiI ₃	83-53	1.7	680	20	
Bi ₂ S ₃	83-16	1.3	1100	200	6.7
Cs ₃ Sb	55-51	1.6	500	10	
PbI ₂	82-53	2.6	8	2	6.2
HgI ₂	89-53	2.1	100	4	6.3
CdTe	48-52	1.5	1100	100	6.1
CdZnTe	48-30-52	1.5-2.4			

Recall correlation of W with band gap – higher W leads to lower signal but also lower thermal noise.



C.A.Klein, J.App. Phys. 39 (1968) 2029

Chap. 13 – Other Semiconductors – CZT

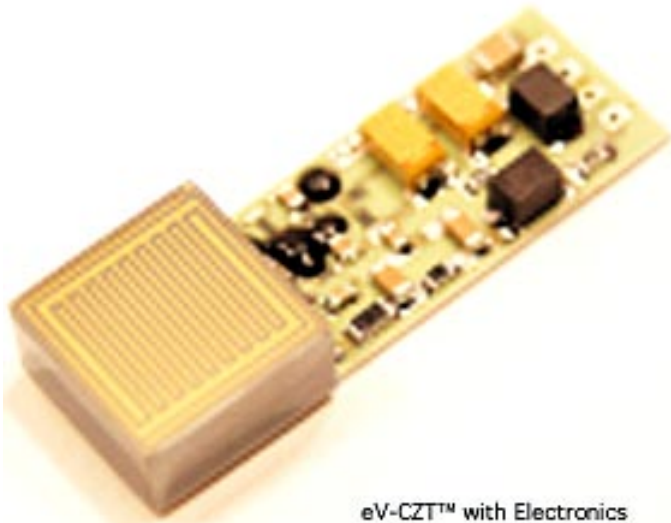

eV-CZT™ with Electronics

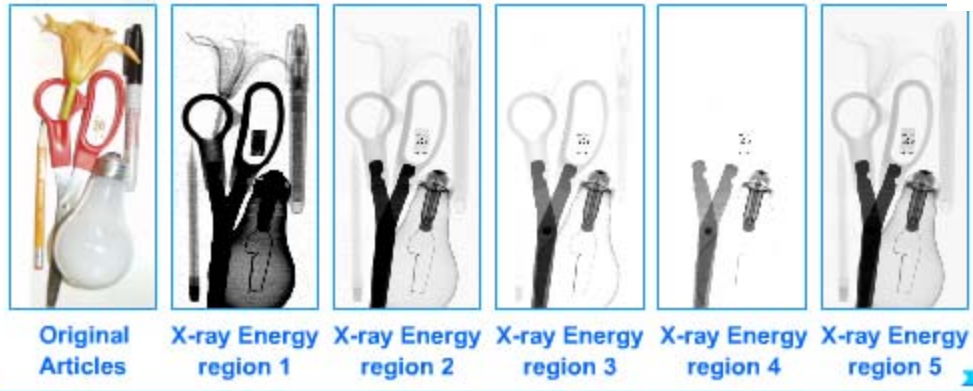
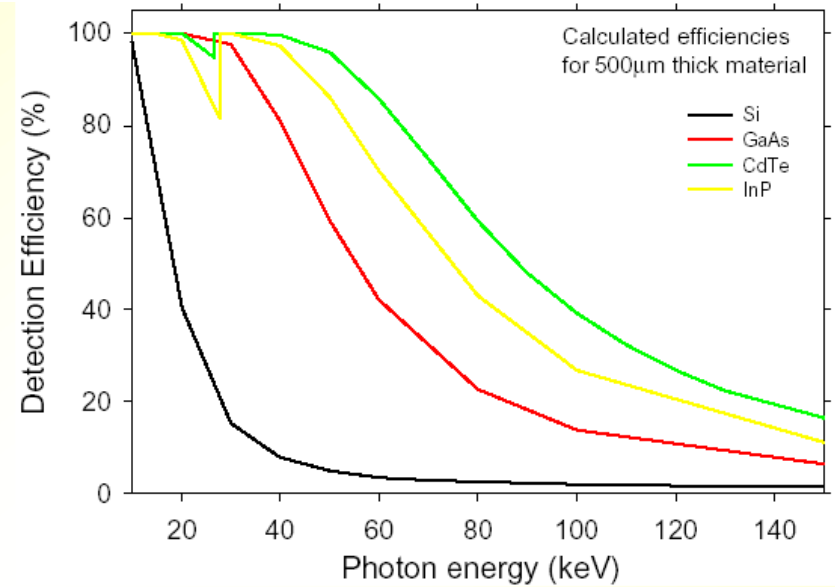

Typical sensitivity of integrated device: 0.1 mRem/hr to 1 Rem/hr

Imaging device, 4.5x4.5x6 mm³ in 4x4 array from BICRON

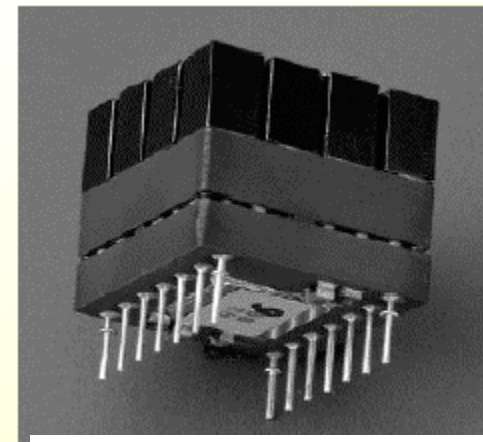

C.Mestais, NIM A458 (2001) 62

Chap. 13 – Position Sensitivity [Simple]

Fig. 13.32 Knoll, 3rd Ed.
(SSB – detector)

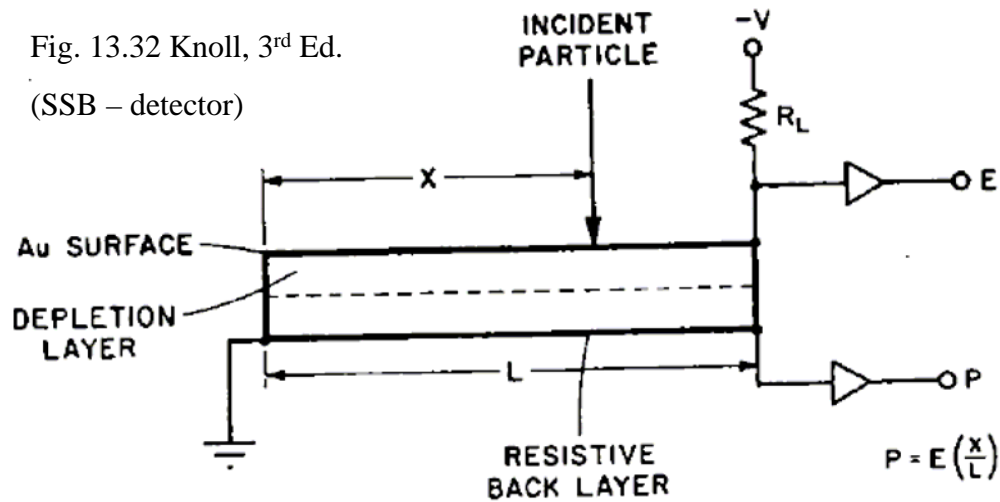

ORTEC PSD n-type, B-contact

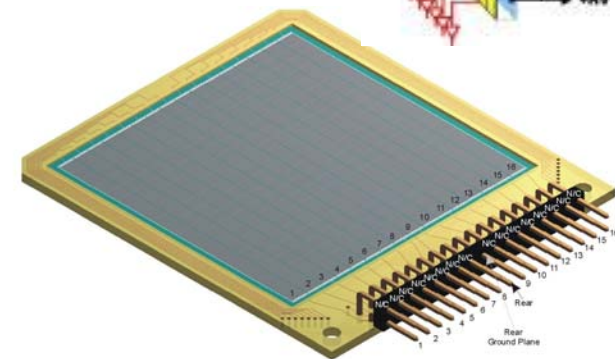
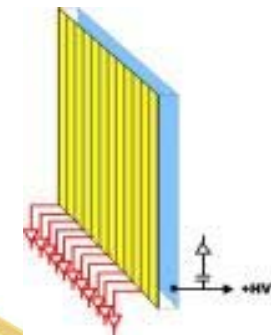
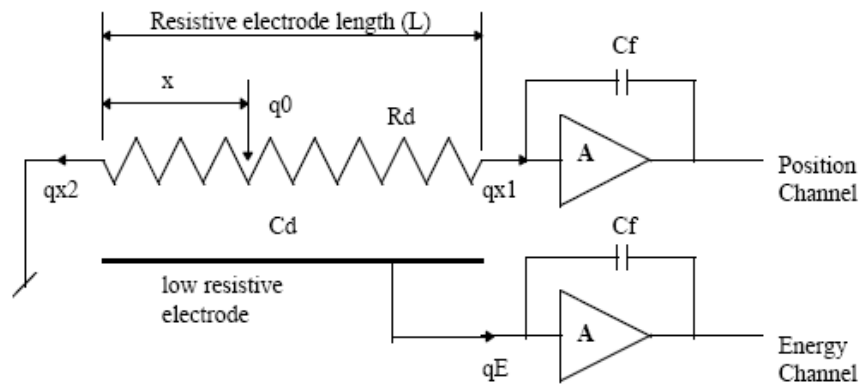

Charge division:
 $q_0 = q_{x1} + q_{x2} + q_E$

Chap. 13 – Position Sensitivity [Patterns]

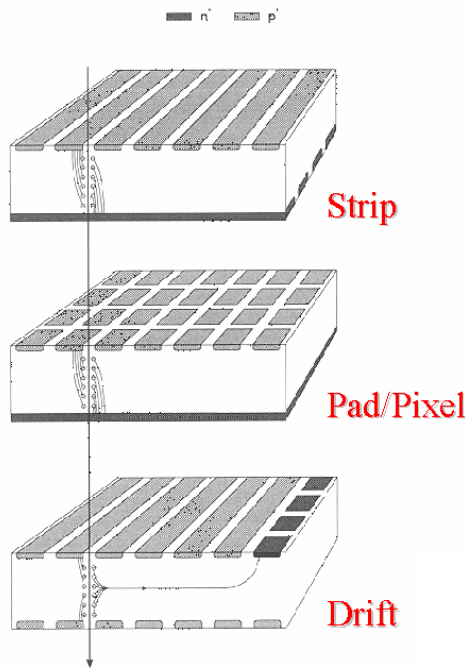
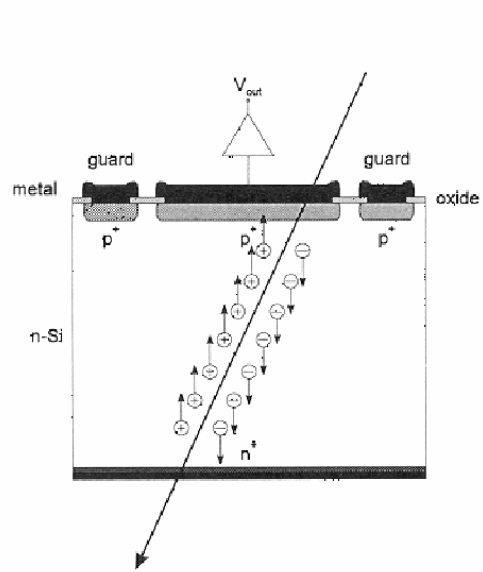

One readout channel / strip

One readout channel / pad

One readout channel / pad & Time

Drift detectors .. Continuous readout

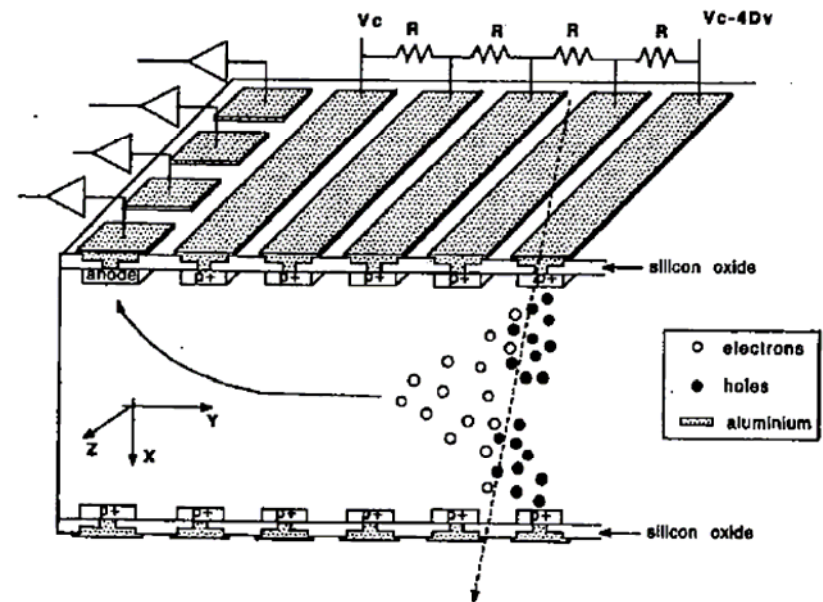

Chap. 13 – Position Sensitivity [CCD]

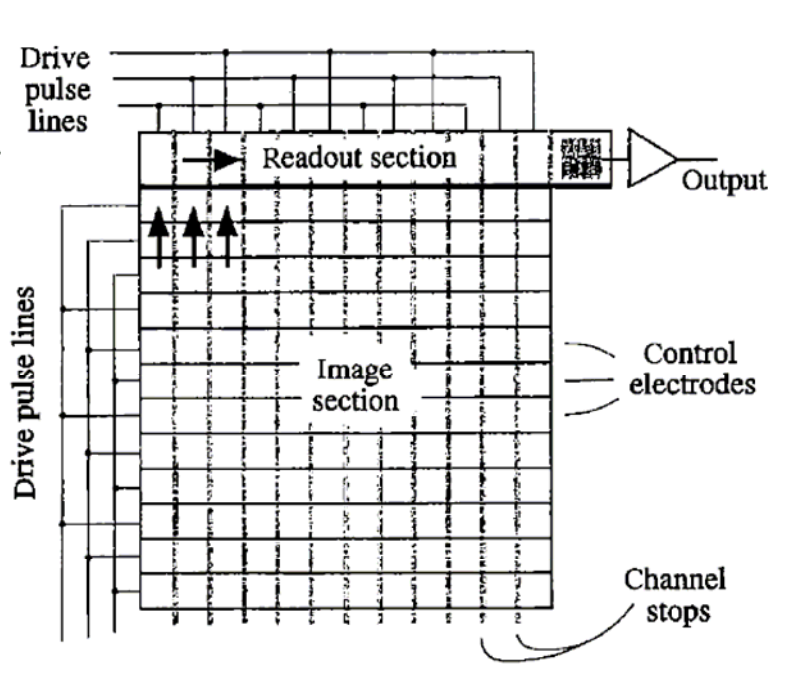

Fig. 13.38 Knoll, 3rd Ed.

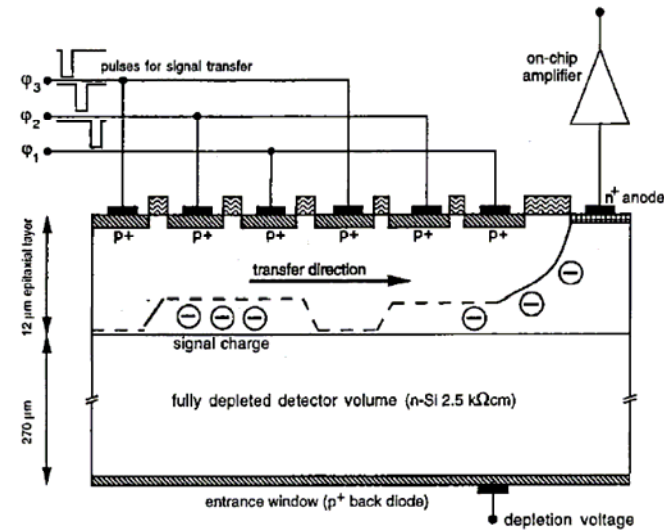

Fig. 13.39 Knoll, 3rd Ed.

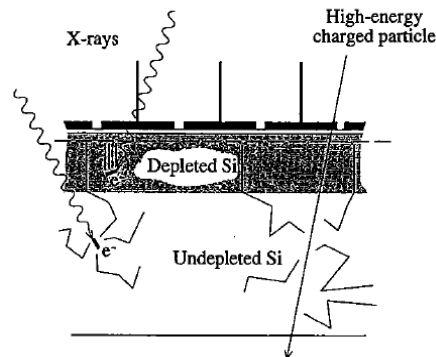

Fig. 13.40 Knoll, 3rd Ed.

Problem 13.8 – A fully depleted silicon CCD is $300\ \mu\text{m}$ thick and used to form a recorded image of incident x-rays whose energy is 10 keV. It has an array of 256×256 pixels per frame and is operated in a simple mode of alternating exposure and readout. The readout frequency is 100 kHz. The exposure time per frame is to be kept at least 20 times the total readout time. The same measurement is designed to measure the energy deposited by each individual x-ray so that probability of multiple hits should be less than 5% per pixel during exposure.

- a) Determine the maximum x-ray interaction rate in the full image.
- b) Find the minimum required storage capacity for electrons in one pixel.
- c) If the charge due to leakage is to be kept less than 10% of the signal charge due to a single x-ray interaction in a pixel, estimate the maximum leakage current for the entire device.